

For doors on escape routes

- The features of this panic device are of utmost importance for people's safety. Therefore in no case may any changes be made to the product.



[www.strandhardware.co.uk/images/PDF/DoPDFineTouchBar.pdf](http://www.strandhardware.co.uk/images/PDF/DoPDFineTouchBar.pdf)

Declaration Of Performance (CE)



[https://www.strandhardware.co.uk/images/UKCA-DOPs/UKCA\\_Panic\\_Hardware\\_SHWUKCA6.pdf](https://www.strandhardware.co.uk/images/UKCA-DOPs/UKCA_Panic_Hardware_SHWUKCA6.pdf)

Declaration Of Performance (UKCA)

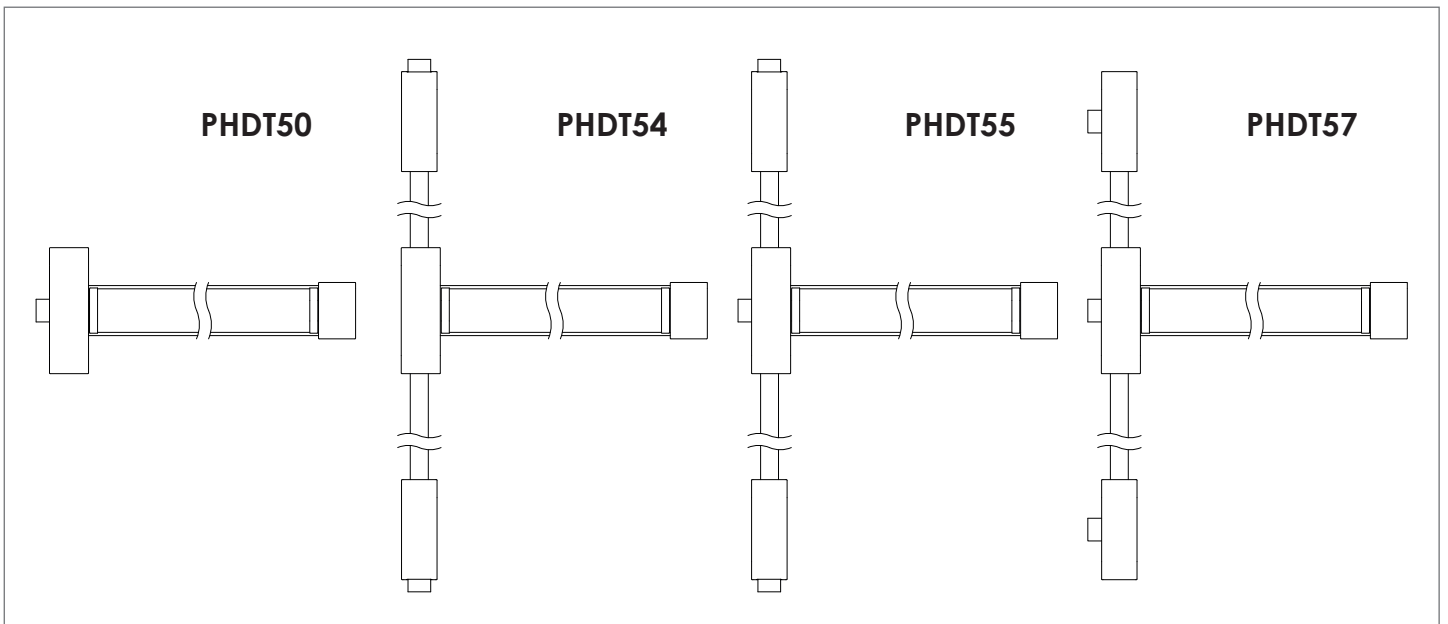

## Machining the profile

- After completing work on the profile, fasten the push bar in place using V3 screws provided (8 self-tapping screw, Ø 3,9mm. Drill a Ø 3,0 mm. hole.)

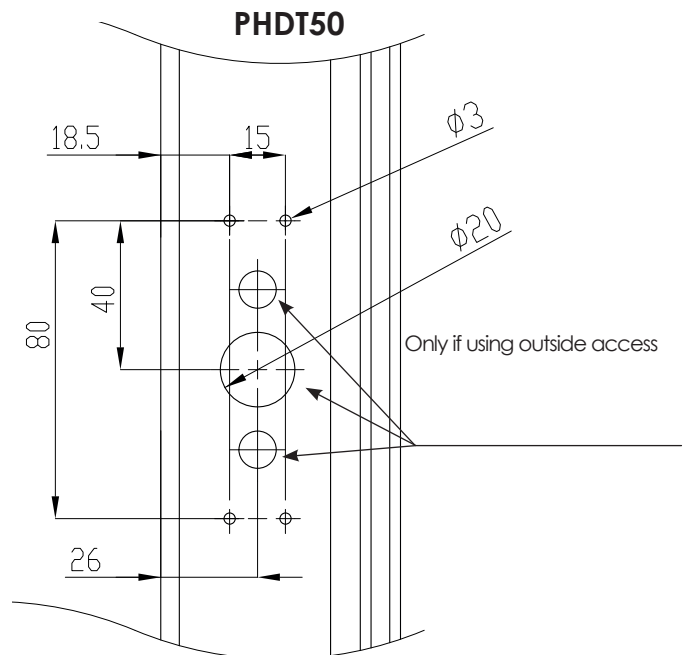



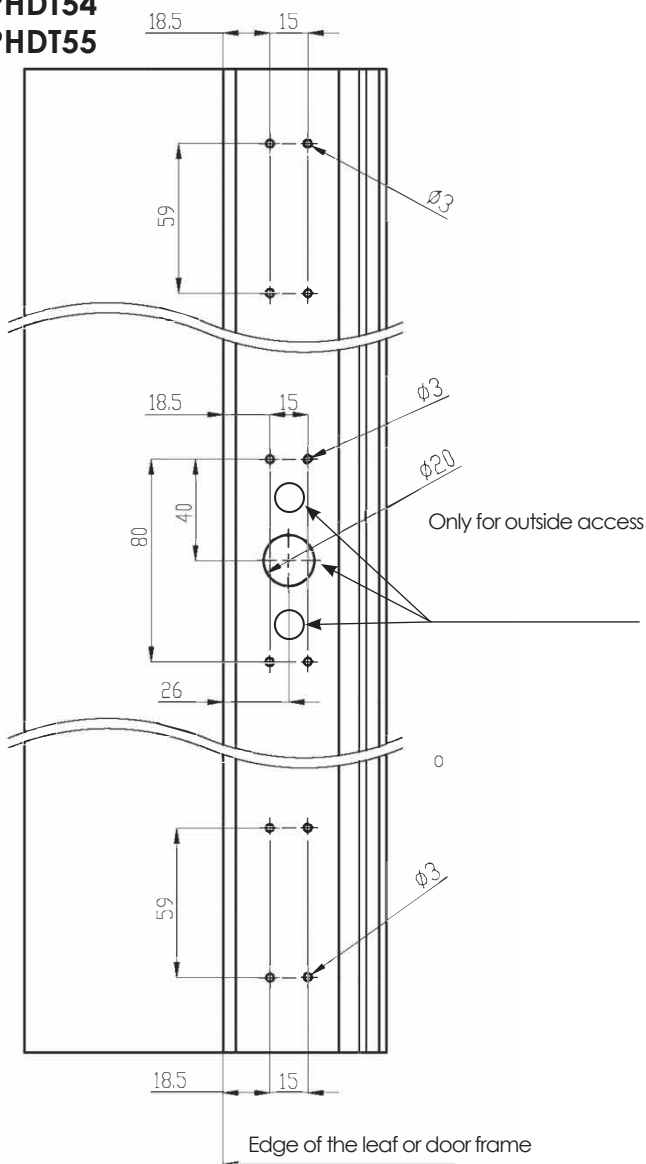

- After completing work on the profile, fasten the push bar in place using V3 screws provided (16 self-tapping screw,  $\varnothing$  3,9mm. Drill a  $\varnothing$  3,0 mm. hole.)

**PHDT54  
PHDT55**

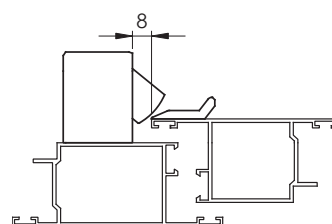
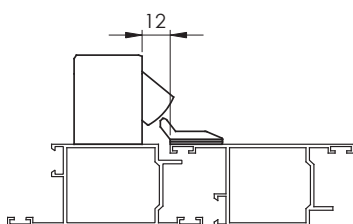
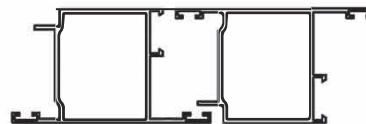
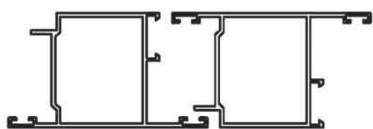
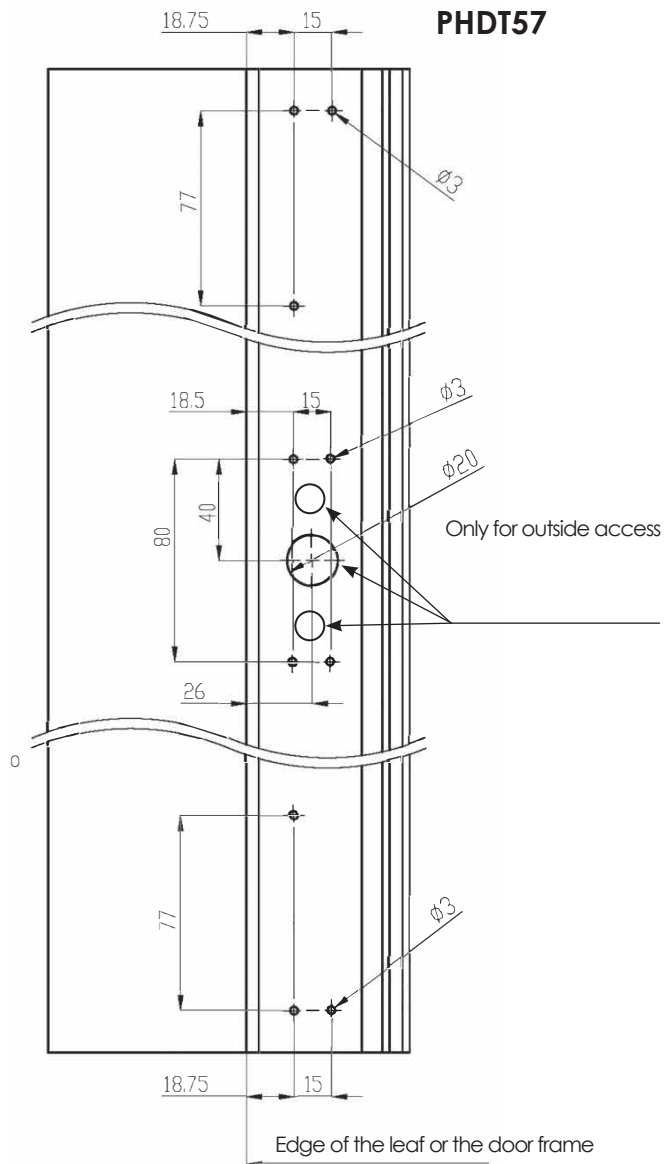

**PHDT57**

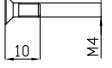

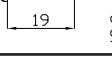
Fixing screws			
V1	3	 Torx T20	
V2	6		

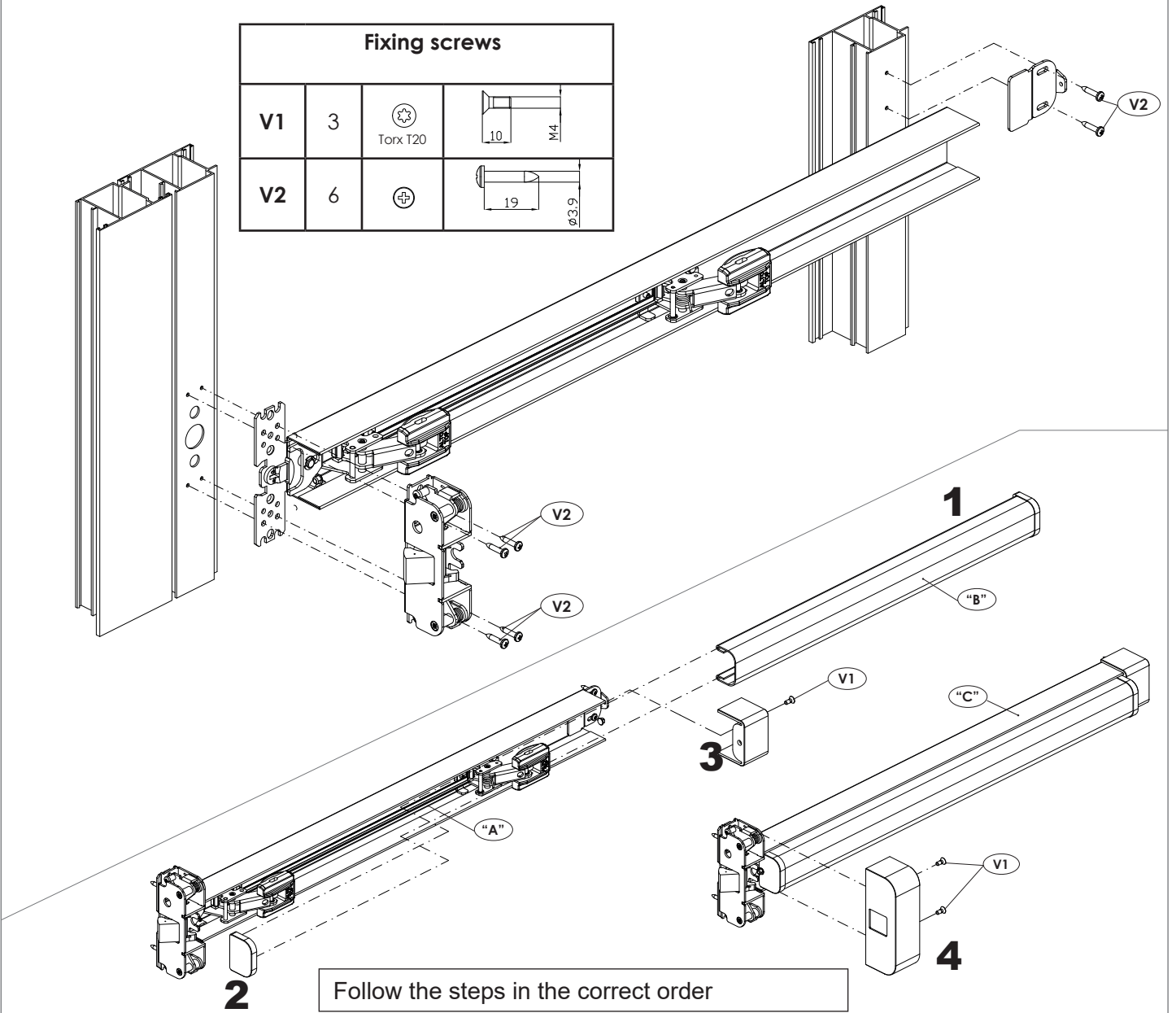

## To reduce bar length

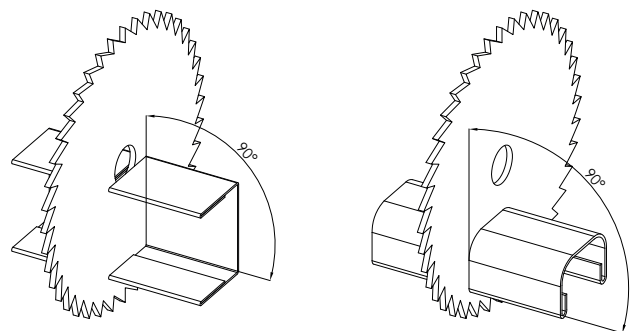
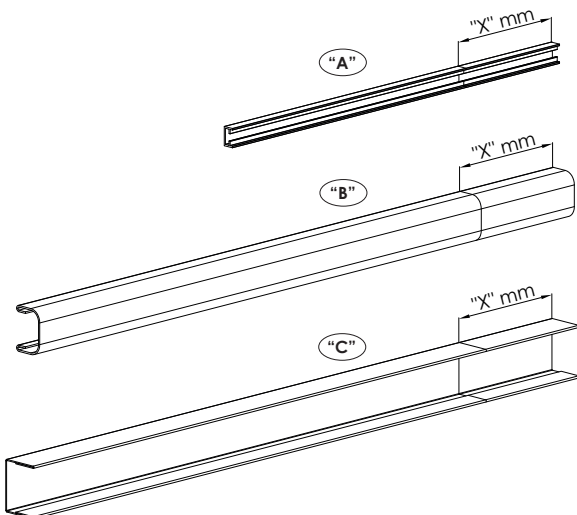

### **ATTENZIONE:**





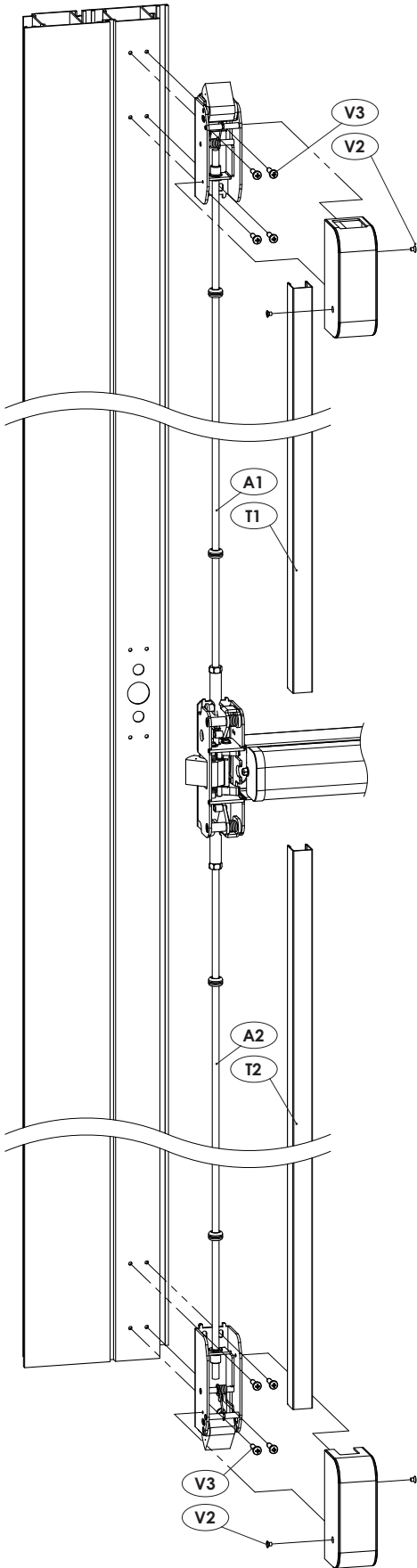

- Ensure all three bars are reduced by the same amount
- Use blade designed to cut stainless steel
- Cut at 90 degrees exactly

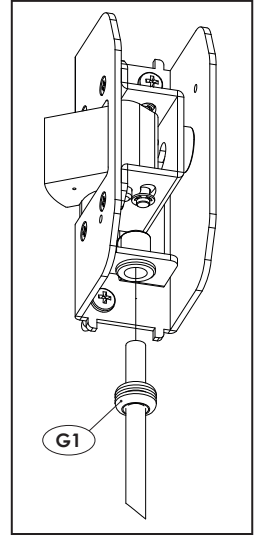
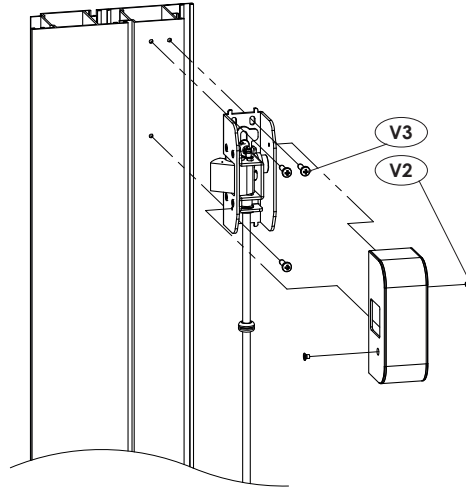
**PHDT54  
PHDT55**

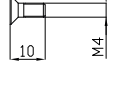

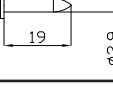
**PHDT57**



Fixing screws			
Fixing screws	Horizontal		Vertical
	Horizontal	Vertical	
<b>V2</b>	4	4	 Torx T20 
<b>V3</b>	6	8	 
<b>D1</b>	2	2	 
<b>G1</b>	4	4	 

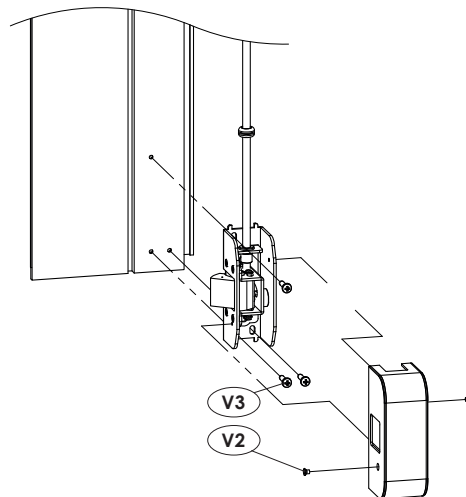
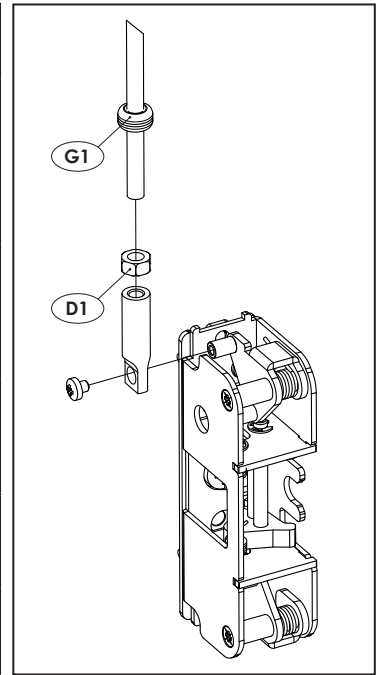

## Threaded rod

## Rod Covers

