

STRAND ANTIPANIC MOTORISED TOUCH BAR

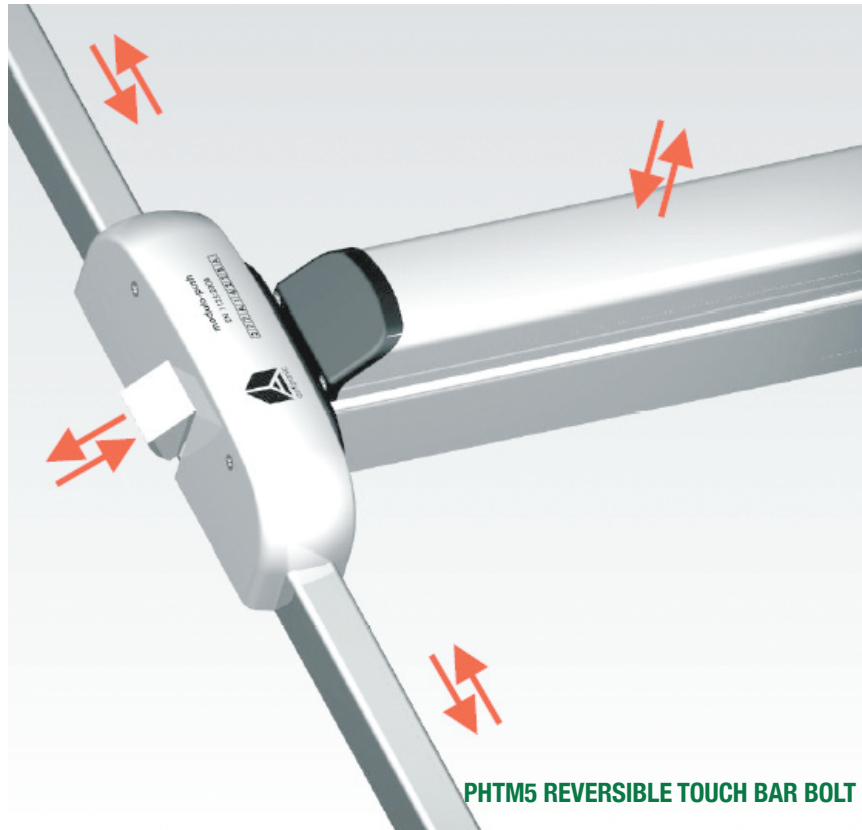

- PHTM0** Motorised single point touch bar latch
- PHTM5** Motorised 3 point touch bar bolt
- PHTM7** Motorised 3 point touch bar latch

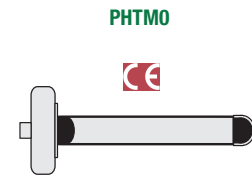

All the devices of Panic Hardware (with full width touch bar) have been tested and certified to BS EN 1125: 2008. This type of device is suitable for all public buildings such as hotels, schools, shops, hospitals, nightclubs etc. where people are unfamiliar with the surroundings.

Strand Antipanic Motorised Touch Bar

Similar in design to the standard touch bar, the motorised touch bar range comprises of modular components - the full width touch bar mechanism can be added with either vertical or side entry pullmans to give variants of one, two/three point latches or two/three point bolts. Supplied with striker plates for timber doors, but also available for PVC-U, aluminium or steel doors. The reversible touch bar mechanism, pullmans and vertical rod covers are available in powder coated finishes of silver or black with green touch bar. It is also available in satin stainless steel plated finish. Other colours are available to order - please enquire for details.

Operation

The motorised touch bar range looks exactly the same as the standard touch bar range, however the operation is very different. From inside the building the touch bar, when operated by hand allows egress in the normal way. The motorised version allows various electronic options to be connected to the device.

So from outside, when activated, an audible signal sounds for a few seconds. At the same time, the motor retracts the latches allowing the door to be pulled open. After a few seconds (variable from 3 - 30 seconds) the motor then drives the latches back into position to secure door.

Outside Access

The motorised touch bar can be connected to a variety of access entry systems such as a digital keypad, proximity reader, swipe card, push button or keyswitch to allow controlled access from outside. An audible signal sounds for a few seconds indicating when the latches are retracting into the open position - allowing access.

The PH391MC external cylinder allows authorised access from outside by a key-holder. Single, two point or three point devices can be operated effortlessly by the turn of a key. In addition a standard OAD can be used as a manual over-ride in the event of power failure. The latches operate on 12-30v DC or 12-20v AC - 1amp power supply.

Alternatively the exit device can be connected to a timed controller to allow free access at any time of day or night.

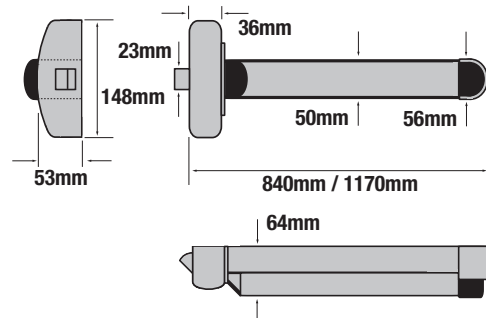

Strand Hardware Limited, Strand House, Long Street,
 Premier Business Park, Walsall, West Midlands WS2 9DY.
 Tel: 01922 639111 Fax: 01922 626025
 Email: info@strandhardware.co.uk
www.strandhardware.co.uk



**STRAND ANTIPANIC MOTORISED TOUCH BAR
PANIC LATCHES PHTM0 / PHTM7**

**PANIC BOLT PHTM5
CLASSIFICATION BS EN1125
(3-7-7-B-1-4-2-2-B-A)**

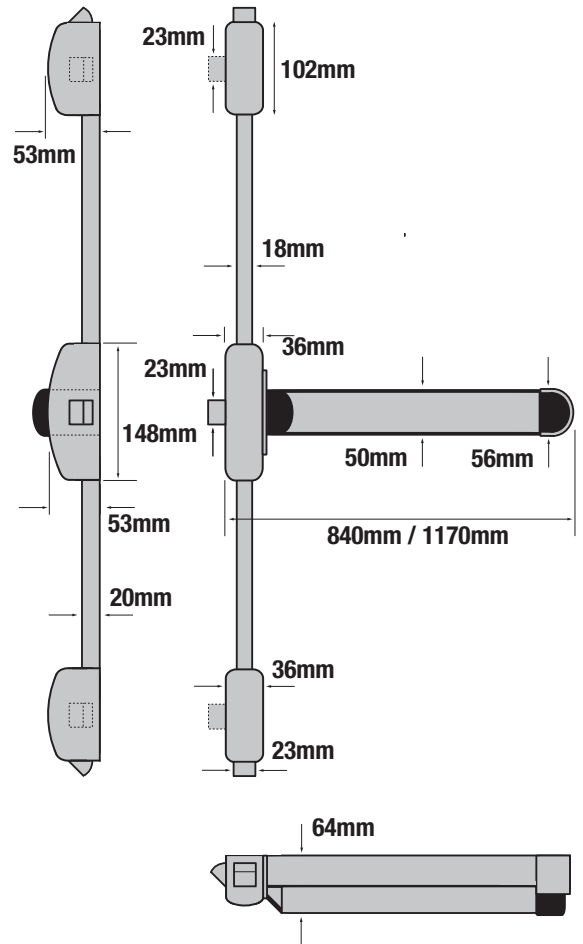
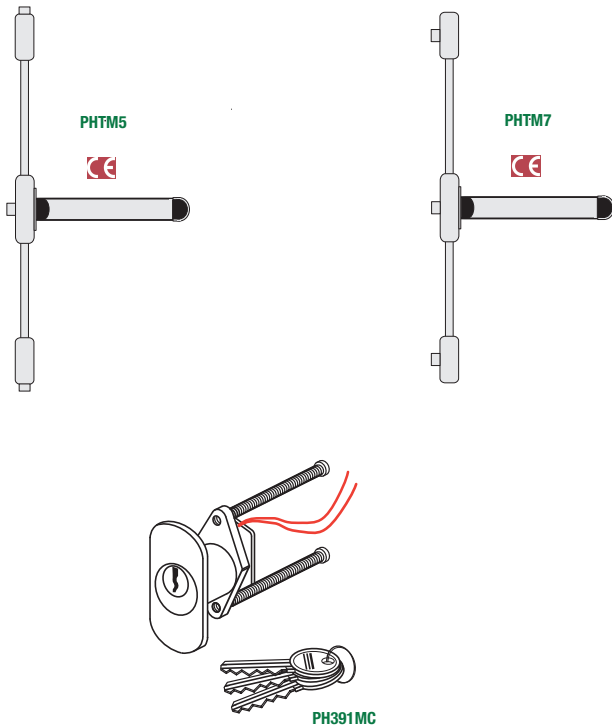

Dogging Facility

The motorised touch bar range has the option of dogging (hold unlocked) as standard. Simply by turning power supply off when latches are retracted allows free access until unit is powered up again.

Please note that current legislation of BS EN1125 specifies that for fire/ smoke door assemblies the panic device shall not include any form of dogging mechanism. Therefore any device incorporating dogging can only be used on escape doors.

Finishes

The finishes below are applicable to all products of the motorised range. Other colours and plated finishes may be produced to special order.

Size of doors

To suit doors up to 2585mm high by 840mm wide - extra wide touch bars of 1170mm are for doors exceeding these dimensions. The 840mm size touch bar can be cut down to a minimum of 700mm.

Fixing

The panic device is entirely surface mounted. It may be necessary to conceal the wiring for connection to outside access switch/controller. Full instructions are supplied with each device.

Packaging

Individually packed in a strong purpose made cardboard carton.

Microswitch

The Motorised range offers the option of a micro-switch housed in the centre mechanism. Please state requirement at time of ordering.

Powder coated	Plated Finishes
Silver EPS (20)	Satin Stainless Steel Plated SSSP (44)
Black with Green cross arm BGN (81)	
Other colours (00) may be produced to special order	



Strand Hardware Limited, Strand House, Long Street,
Premier Business Park, Walsall, West Midlands WS2 9DY.
Tel: 01922 639111 Fax: 01922 626025
Email: info@strandhardware.co.uk
www.strandhardware.co.uk

